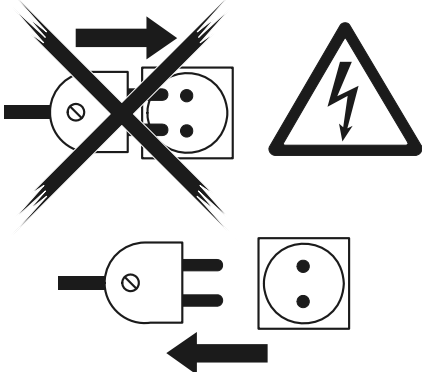
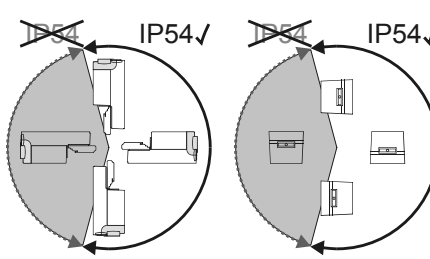
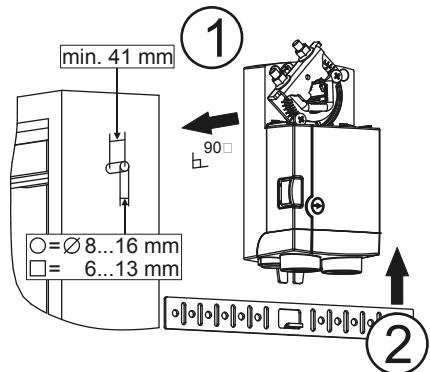
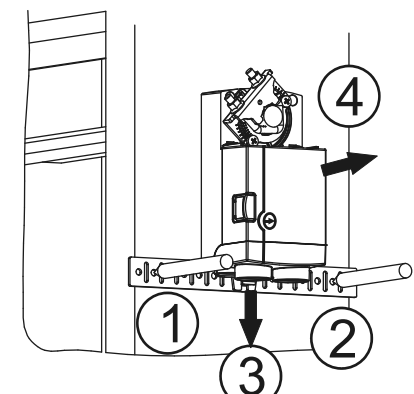
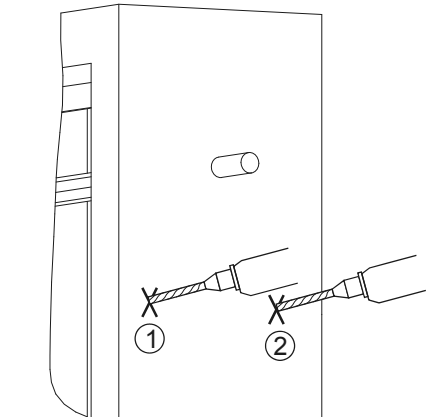
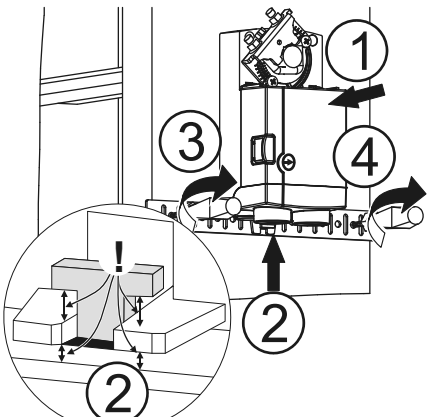

D Montageanweisung
DK Installationsvejledning
ES Instrucciones de montaje
F Instructions d'installation
I Istruzioni di montaggio
N Installationsinstruktioner
NL Installatievoorschrift
P Instruções de montagem
S Installation instruktioner
FI Asennusohje

CNxx05 / CNxx10 NON-SPRING RETURN DIRECT-COUPLED DAMPER ACTUATORS

INSTALLATION INSTRUCTIONS

<p>E Keep these instructions together with the actuator or with the equipment documentation! Only qualified personnel may perform electrical connections for 230 VAC. Caution! Do not improperly open the actuator.</p>	<p>F Cette instruction est à conserver avec le servo-moteur ou avec la documentation de l'installation ! Le raccordement électrique de servo-moteur pour le 230 V AC ne peut être effectué que par le personnel autorisé. Attention ! Le servo-moteur ne doit pas être ouvert non-conformément.</p>	<p>P Guarde estas instruções junto do actuador ou junto da documentação da instalação! A ligação eléctrica do actuador a 230 V AC só deve ser efectuada por pessoal especializado. Atenção! O actuador não deve ser aberto de forma inadequada.</p>
<p>D Diese Anleitung ist beim Antrieb oder in der Anlagen-dokumentation aufzubewahren! Elektrisches Anschließen von Antrieben für 230 V AC ist nur durch autorisiertes Fachpersonal gestattet. Achtung! Der Stellantrieb darf nicht unsachgemäß geöffnet werden.</p>	<p>I Queste istruzioni devono essere conservate insieme al servocomando o con la documentazione dell'impianto! I collegamenti a 230 V c.a. devono essere eseguiti da personale qualificato. Attenzione! Il servocomando non deve essere aperto impropriamente.</p>	<p>S Denna instruktion skall förvaras tillsammans med ställdonet eller anläggningsdokumentationen! Elektrisk anslutning av ställdon med 230 V AC får endast utföras av behörig personal. OBS! Ställdonet får endast öppnas på ändamålsenligt sätt.</p>
<p>DK Opbevar denne vejledning sammen med motoren eller med anlægsdokumentationen! Elektrisk tilslutning af motorer for 230 V AC bør kun foretages af autoriserede personer. OBS! Forsøg ikke at adskille motoren.</p>	<p>N Denne vejledningen skal opbevares sammen med motoren eller anlæggsdokumentationen! Elektrisk tilkopling av motorer med 230 V AC må kun udføres av fagfolk. OBS! Motoren må ikke åpnes av ukyndige.</p>	<p>FI Tätä ohjetta tulee säilyttää toimimoottorin läheisyydessä tai yhdessä laitosdokumenttien kanssa! Ainoastaan asiaankuuluvat oikeudet omaavat henkilöt saavat tehdä käyttöjännitteen 230 VAC liitäntöitä. Huomio! Toimimoottoria ei saa (ellei käyttöohjessa ole toisin mainittu) avata.</p>
<p>ES Conserve estas instrucciones con el actuador o con la documentación de la instalación. La conexión eléctrica del actuador a 230 V CA debe hacerse solamente por personal cualificado. Atención! El actuador no debe ser abierto de manera inadecuada.</p>	<p>NL Deze handleiding moet bij de servomotor, of met de documentatie van de installatie worden bewaard! De elektrische aansluiting van servomotoren voor 230 Vac mag alleen door geautoriseerd personeel worden uitgevoerd. Opgelet! Wees voorzichtig met het openen servomotor!</p>	
<p>A1</p> 	<p>A2</p> 	<p>A3</p> 
<p>A4</p> 	<p>A5</p> 	<p>A6</p> 

- | | | |
|--|---|---|
| D Montage auf links (CCW) oder rechts (CW) schließender Klappe | I Montaggio su farfalla con chiusura sinistrorsa (CCW) o destrorsa (CW) | S Montage på vänsterstängande (CCW) eller högerstängande (CW) spjäll |
| DK Montering på spjæld, som lukker til venstre (CCW) eller til højre (CW) | N Montering på spjæld som lukker til venstre (CCW) eller høyre (CW) | FI Asennus vasemmalle (CCW) tai oikealle (CW) sulkeutuvalle pellille |
| ES Montaje sobre la compuerta que cierra a izquierda (CCW) o a derecha (CW) | NL Montage op links (CCW) of rechts (CW) sluitende klep | |
| F Montage sur un clapet fermant à gauche (CCW) ou à droite (CW) | P Montagem em tampa de fechar para a esquerda (CCW) ou para a direita (CW) | |

MOUNTING ON COUNTERCLOCKWISE (CCW) OR CLOCKWISE (CW) CLOSING DAMPER

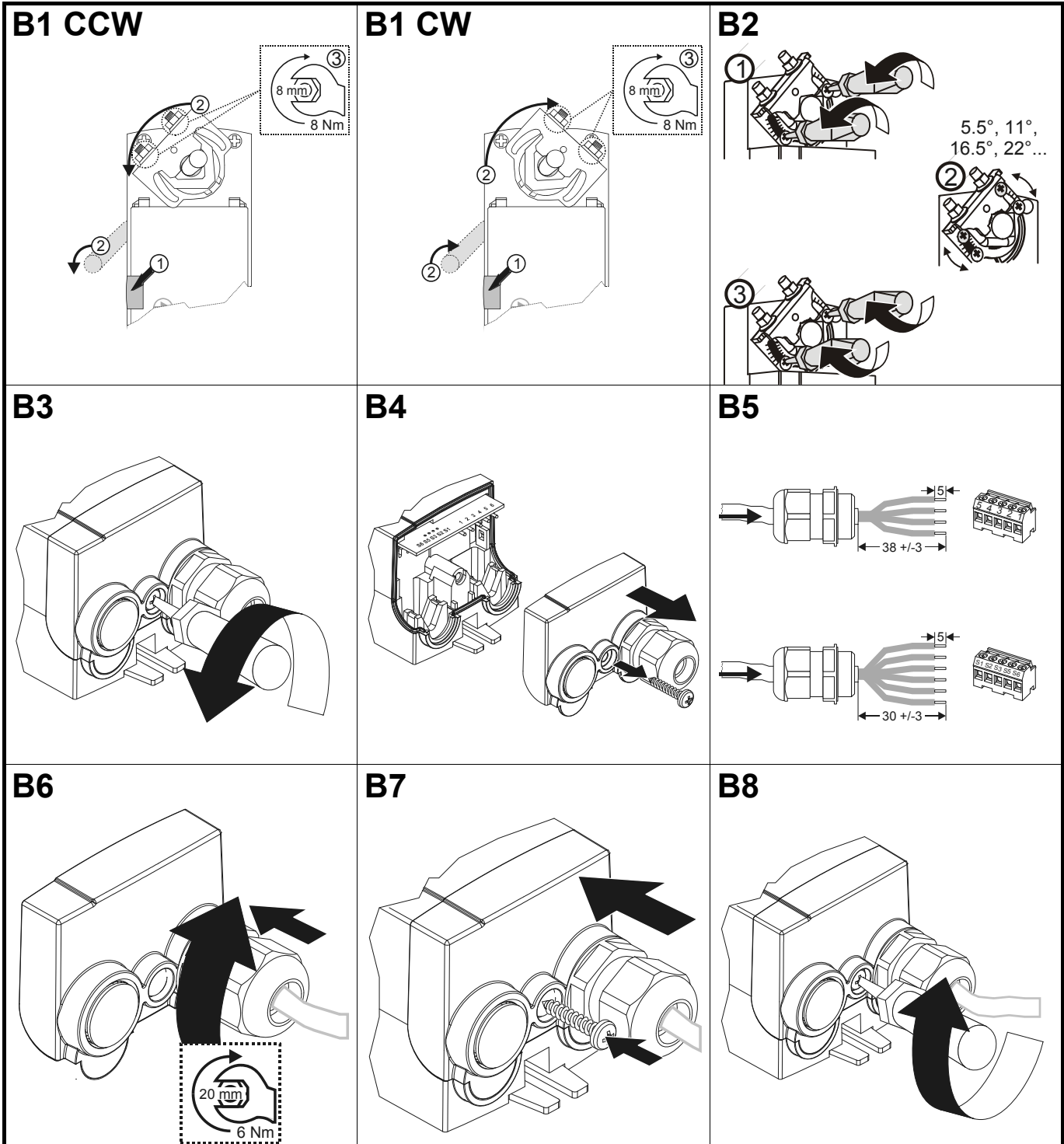

E	wiring	2-position control	Floating control	Feedback	Modulating control	End switches
D	Verkabelung	2-Positionen-Steuerung	3-Pos.-Regelung	Rückmeldung	Stetige Regelung	Endschalter
DK	Ledninger	Tænd / sluk kontakt	Glideregulering	Feedback	Modulerende regulering	Ekstra kontakter
ES	Cableado	Control de 2 posiciones	Control flotante	realimentación	Control modulante	Interruptores auxiliares
F	Câblage	Interrupteur 2 positions	Commande flottante	réroaction	Commande modulante	Interrupteurs supplémentaires
I	Cablaggio	Controllo di due posizioni	Controllo flottante	feedback	Controllo modulato	Interruttori ausiliari
N	Ledningsnett	To-plas-serings-betjening	Flytende kontroll	Feedback	Modulerende kontroll	Tilleggs-brytere
NL	Bedrading	Twee positie schakelaar	Zwevende regeling	Feedback	Modulatie-regeling	Extra schakelaars
P	Cablagem	Comando de 2 posições	Controlo flutuante	realimentação	Controlo de modulação	Interruptores auxiliares
S	Kablage	Till- / Från-kopplare	Flytande reglering	Feedback	Modulerande reglering	Ytterligare omkopplare
FI	Kaapelointi	Päälle- / pois-kytkin	Liukuohjaus	Feedback	Modulaatio-ohjaus	Lisäkytkin

WIRING

C1: CN7505, CN7510

Modulating: 0[2]...10V, 10...0[2]V

24V~/=

1 24V~/+

2 GND/-

3 Y in 0[2]...10V

4 POS 50%

5 POS out 0[2]...10V

! = override option

Floating: Dir ↷

24V~/=

1 24V~/+

2 GND/-

3 CW

4 CCW

5 POS out 0[2]...10V

! = feedback option

2-Position: Dir ↷

24V~/=

1 24V~/+

2 GND/-

3 CW

4 CCW

5 POS out 0[2]...10V

! = feedback option

C2: CN4605, CN4610

2-Position: Dir ↷

1 230V~

2 CW

3 CCW

4 L

5 N

> 3 mm!

230V ~

C3: CN6105, CN6110

Floating: Dir ↷

24V~/=

1

2 GND/-

3 CW

4 CCW

5

!

2-Position: Dir ↷

24V~/=

1

2 GND/-

3 CW

4 CCW

5

!

C4

END SWITCHES
(max. 230 V, 5 A)

A,B: C S1

A: NC S2

A: NO S3

B: NC S5

B: NO S6

- | | | |
|--|--|---|
| D Einstellung für links (CCW) oder rechts (CW) schließender Klappe / Synchronisation | I Regolazione per farfalla con chiusura sinistrorsa (CCW) o destrorsa (CW) / Sincronizzazione | S Ställning på vänsterstängande (CCW) eller högerstängande (CW) spjäll / Synchronisering |
| DK Justering på spjæld, som lukker til venstre (CCW) eller til højre (CW) / Synchronisering | N Justering på spjæld som lukker til venstre (CCW) eller højre (CW) / Synchronisering | FI Säätö vasemmalle (CCW) tai oikealle (CW) sulkeutuvalle pellille / Synchronointi |
| ES Ajuste para la compuerta que cierra a izquierda (CCW) o a derecha (CW) / Sincronización | NL Regeling voor links (CCW) of rechts (CW) sluitende klep / Synchronisatie | |
| F Ajustement pour un clapet fermant à gauche (CCW) ou à droite (CW) / Synchronisation | P Adaptação para tampa de fechar para a esquerda (CCW) ou para a direita (CW) / Synchronization | |

ADJUSTING FOR COUNTERCLOCKWISE (CCW) OR CLOCKWISE (CW) CLOSING DAMPER / SYNCHRONIZATION

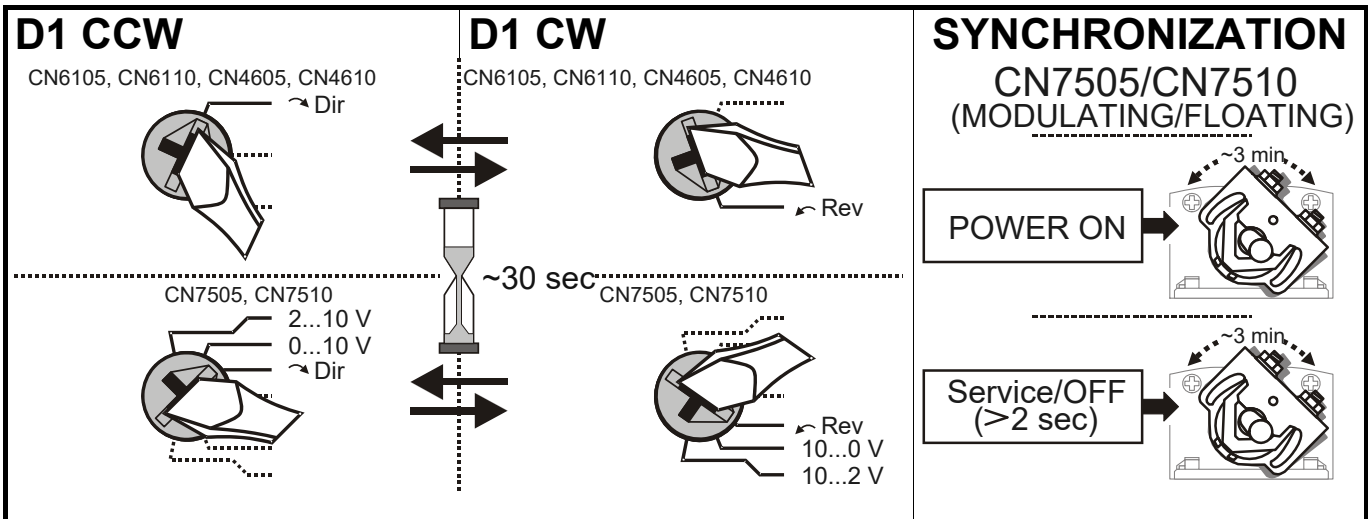

Security Considerations:

1. This device should be installed in locked cabinet, operated by authorized technician;
2. Don't connect with unauthorized device;
3. Access <https://www.honeywell.com/contact-us/vulnerability-reporting> for vulnerability reporting.



Automation and Control Solutions
 Honeywell International Inc.
 1985 Douglas Drive North
 Golden Valley, MN 55422

Honeywell (Tianjin) Limited
 66, BaiHe Road, TEDA
 Tianjin, 300457, P.R.C.



Printed in China, on recycled paper containing at least 10% post-consumer paper fibers.