

### 法兰式动态压差平衡阀 Flanged Differential Pressure Balancing Valve

#### 安装说明 INSTALLATION INSTRUCTIONS

#### A 管道安装 Installation

建议阀门手轮向上安装

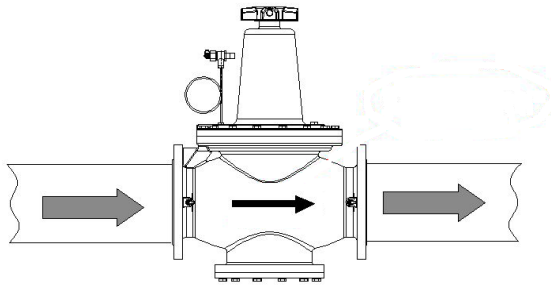

本产品仅适用满足国家标准GB/T 29044-2012采暖空调系统水质的介质，如果拟应用其他介质，请先咨询霍尼韦尔公司！

#### A1 将三通测量头安装在静态阀上 Connect three way measure cocks with static balancing valves

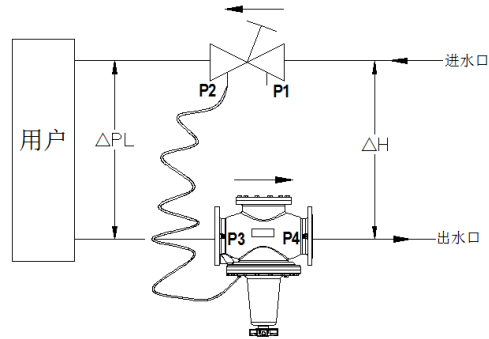

三通测压头应与静态阀低压出口端连接  
Connect with low pressure terminal of static balancing valve

#### B 安装调试 Commissioning

#### B1 打开三通测量头 Open three way measure cocks

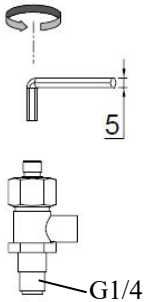

#### B2 打开阀门排气孔的堵头 Open plug of vent B3 排气 Exhaust

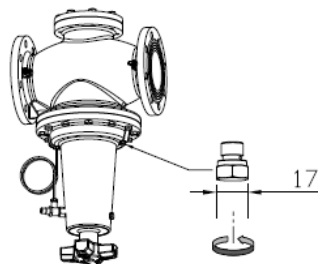

#### B4 关闭阀门排气孔的堵头 Close plug of vent

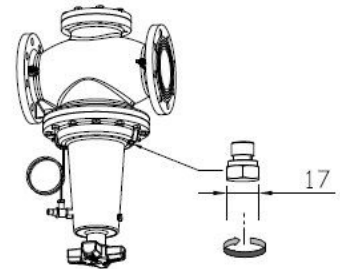

#### B5 使用压力表测量P2和P3之间压差，调节手轮，设置被控压差 Measure the DP between P2 and P3 with the pressure gauge and rotate the handwheel to set the controlled DP.

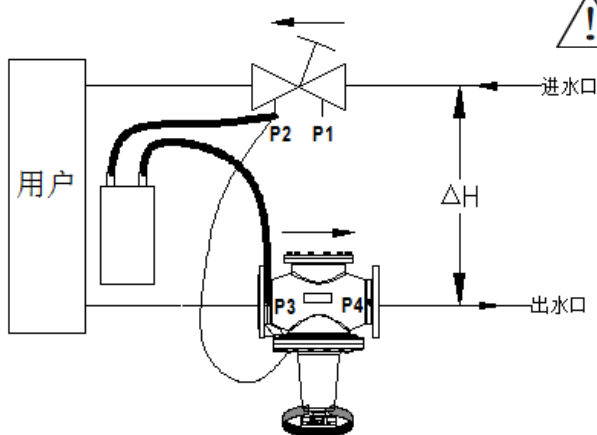

a. 当  $\Delta H > 2 * \Delta PL$  时，压差平衡阀开始工作  
When  $\Delta H > 2 * \Delta PL$ , the DPCV starts to work.  
b. 必须使用配给的导压管，否则影响调试效果。导压管长度  $\leq 2m$   
The matching capillary pipe must be used, otherwise it will affect the debugging result. The length of capillary pipe  $\leq 2m$ .

#### C 关断功能 Shut off function

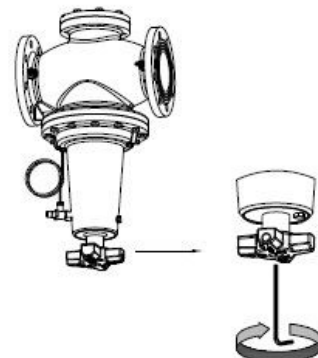

## 产品型号Product OS#

产品型号SKU	阀门口径Size	PN	压差控制范围DP Range kPa	连接方式 Connection	流量最大值 Q <sub>max</sub> m <sup>3</sup> /h	流量最小值 Q <sub>min</sub> m <sup>3</sup> /h
VDP065L	DN65	16	20-80	法兰	35.9	0.5
VDP065H	DN65	16	40-160	法兰	47.2	1.4
VDP080L	DN80	16	20-80	法兰	51.5	0.6
VDP080H	DN80	16	40-160	法兰	70.3	2
VDP100L	DN100	16	20-80	法兰	99	4.2
VDP100H	DN100	16	40-160	法兰	139.9	4.9
VDP125L	DN125	16	20-80	法兰	149	6.2
VDP125H	DN125	16	40-160	法兰	207.7	8.3
VDP150L	DN150	16	20-80	法兰	190	6.3
VDP150H	DN150	16	40-160	法兰	253.5	10.6
VDP200L	DN200	16	20-80	法兰	213.8	9.5
VDP200H	DN200	16	40-160	法兰	343.8	12.2
VDP250L	DN250	16	20-80	法兰	240	10.8
VDP250H	DN250	16	40-160	法兰	366.3	13.6

## 尺寸图 Dimensions

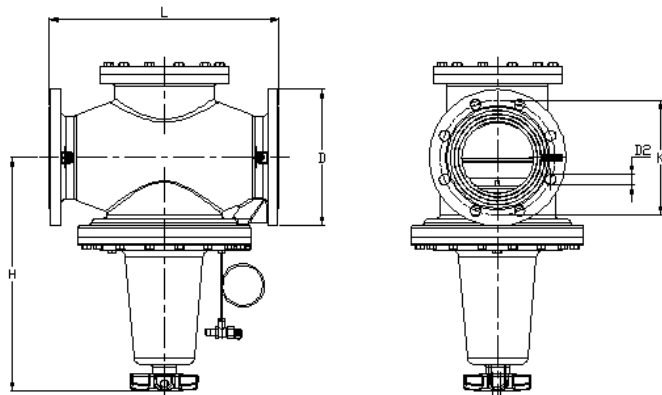

阀门口径Size	D2(mm)	K(mm)	D(mm)	L(mm)	H(mm)	重量(Kg) Weight
DN65	4-18	145	185	290	410	28.9
DN80	8-18	160	200	310	440	34.6
DN100	8-18	180	220	350	480	50.3
DN125	8-18	210	250	400	500	69.4
DN150	8-22	240	285	480	540	99.6
DN200	12-23	295	340	500	614	161
DN250	12-28	355	405	600	704	237

**Honeywell**

霍尼韦尔环境自控产品（天津）有限公司  
 天津经济技术开发区南海路158号  
 邮编：300457  
 电话：+86-22-66287000  
 传真：+86-22-25325214

说明书如有变动，不另行通知。