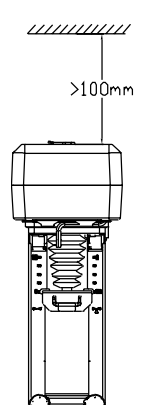
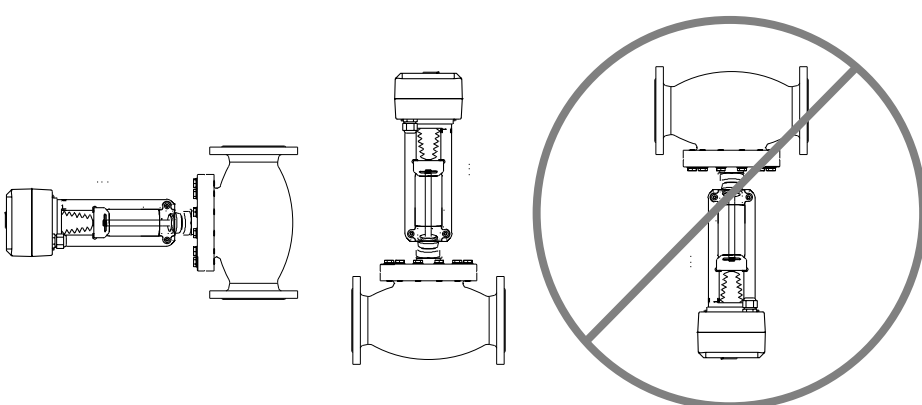
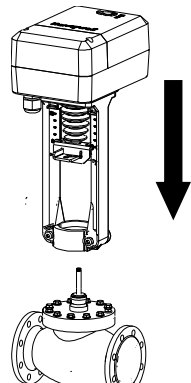
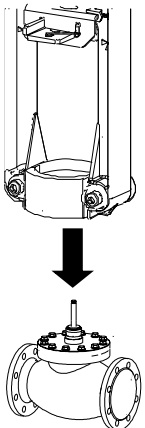
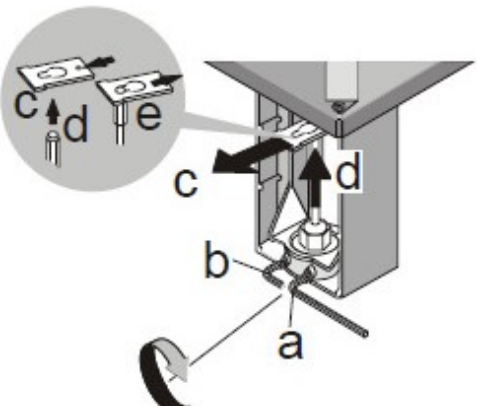
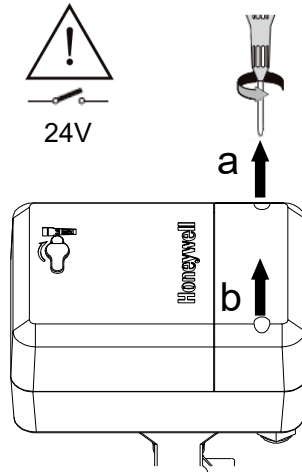
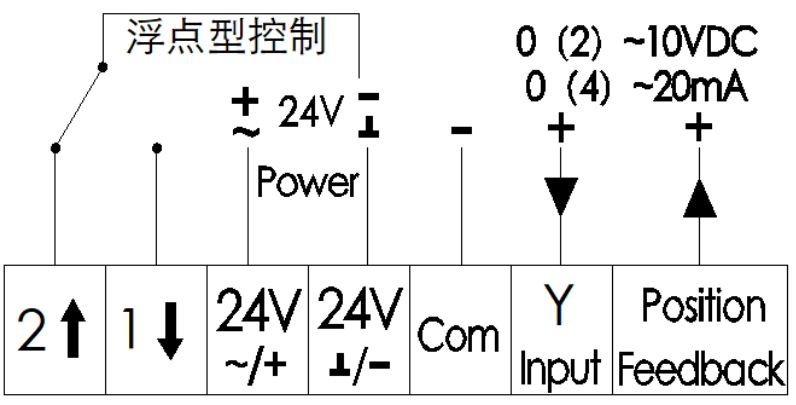

ML8824A系列

线性电动阀门执行器

安装说明

		
<p>A1-A6: 安装</p> 	<p>A1</p> 	<p>A2</p> 
<p>A3</p> 	<p>A4</p> <div style="text-align: center;"> <p>浮点型控制</p>  </div> <p>说明：1. 浮点型控制（第S2-8位拨码开关为ON） 2. 使用浮点型时输入信号无效</p>	

A5: 自适应

上电自适应（出厂默认设置）： 执行器供电后直接进入自适应模式，此时执行器PCB中指示灯黄灯闪烁（1Hz），执行器将自动全关（运行到底部）然后全开（运行到顶部）。指示灯不再闪烁表示过程完成。此过程完成后，执行器运行到指定控制信号位置。

手动自适应（S2-7位拨码为OFF）： 按住电路板上的按钮S1约5秒以上（如图），直到指示灯开始闪烁（1Hz），此时进入自适应模式，现象与上电自适应一致。

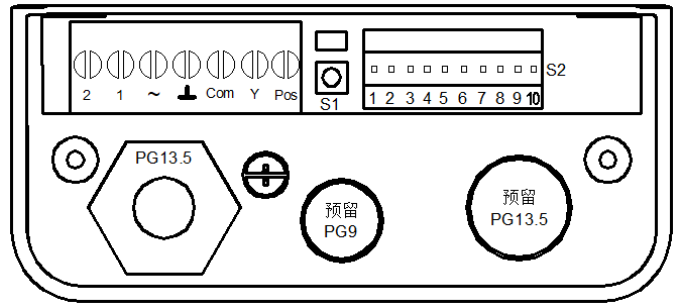

A6

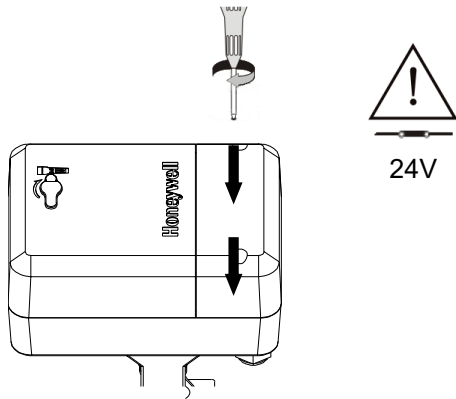

B: 手动操作

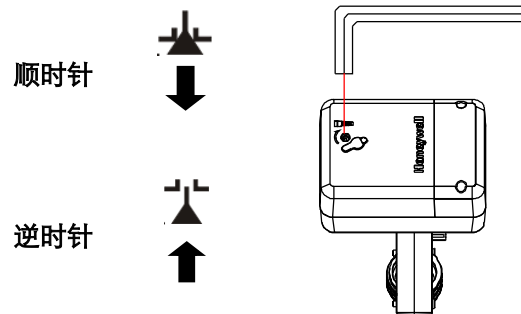

拨码开关设置

拨码	功能	设定值	功能描述
S2-1	控制/反馈信号设定	ON	20%: 控制/反馈信号为4~20mA或2~10VDC
		OFF	0: 控制/反馈信号为0~20mA或0~10VDC (默认设置)
S2-2	控制信号类型设定	ON	II: 电流控制
		OFF	UI: 电压控制 (默认设置)
S2-3	控制信号输入阻抗匹配设定	ON	UI: 控制信号为电压 (默认设置)
		OFF	II: 控制信号为电流
S2-4	阀位反馈信号类型设定	ON	IO: 反馈电流信号
		OFF	UO: 反馈电压信号 (默认设置)
S2-5	工作模式设定	ON	DA: 控制信号增大时执行器向下运动, 控制信号减小时执行器向上运动
		OFF	RA: 控制信号增大时执行器向上运动, 控制信号减小时执行器向下运动 (默认设置)
S2-6	断信号模式设定	ON	DW: 控制信号为电压或电流时, 如信号线被切断, 执行器内部会自动提供一个最小控制信号 (默认设置)
		OFF	UP: 1) 控制信号设定为电压时, 如信号线被切断, 执行器内部会自动提供一个最大控制信号 2) 控制信号设定为电流时, 如信号线被切断, 执行器内部会自动提供一个最小控制信号
S2-7	自适应模式设定	ON	DF: 上电自适应模式 (默认设置)
		OFF	RF: 手动自适应模式
S2-8	控制模式设定	ON	浮点型控制
		OFF	比例调节型控制 (默认设置)
S2-9	保留		
S2-10	速度设定	ON	600N高速: 3s/mm; 1800N高速: 2s/mm
		OFF	600N低速: 4s/mm; 1800N低速: 3s/mm (默认设置)

ML8824A Series Linear Electric Valve Actuator

INSTALLATION INSTRUCTIONS:

<p>A1-A6: Installation</p>	<p>A1</p>	<p>A2</p>
<p>A3</p>	<p>A4</p> <p>Instructions:</p> <ol style="list-style-type: none"> 1. Floating control (when dip switch S2-8 is set to ON) 2. Input signal is invalid when using floating control. 	

A5: Self-Adaption Mode

Power-on self-adaption: The actuator will directly enter into self-adaption mode after being powered up. Meanwhile, the yellow indicator on PCB blinks (1Hz) and the actuator will be automatically full off (traveling to the bottom) and then full on(traveling to the top). When the indicator stops blinking, it means that the process is completed. Afterwards, the actuator will travel to the designated position of control signal.

Manual self-adaption: Press and hold button S1 on PCB for more than 5s (See Fig. 1) until the indicator starts blinking (1Hz) to enter into self-adaption mode. The phenomenon will be the same as power-on self-adaption.

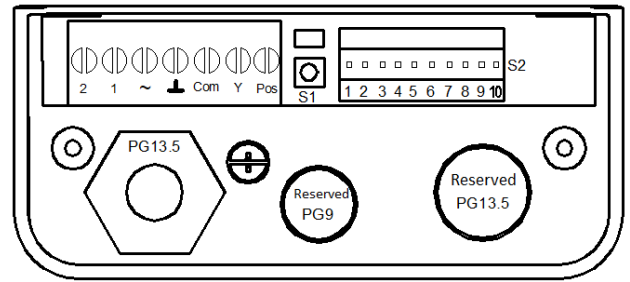

A6

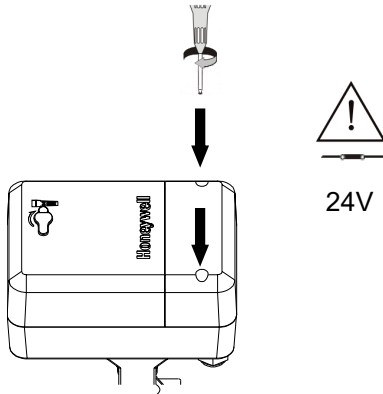

B:Manual

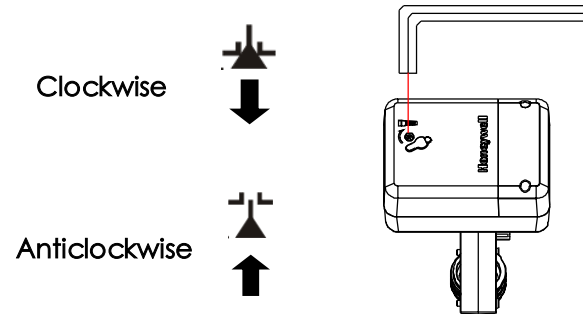

DIP Switch Setting

DIP	Function	Function Description of Setting Value	
S2-1	Setting of control/feedback signal	ON	20%: The control/feedback signal is 4~20mA or 2~10VDC
		OFF	0: The control/feedback signal is 0~20mA or 0~10VDC (factory default)
S2-2	Setting of control signal type	ON	II: The control signal is current type.
		OFF	UI: The control signal is voltage type. (factory default)
S2-3	Setting of control signal input impedance	ON	UI: The control signal is voltage type. (factory default)
		OFF	II: The control signal is current type.
S2-4	Setting of valve position feedback signal type	ON	IO: The valve position feedback signal is current type.
		OFF	UO: The valve position feedback signal is voltage type. (factory default)
S2-5	Setting of operating mode	ON	DA: When control signal increases, actuator moves downward. When control signal decreases, actuator
		OFF	RA: When the control signal increases, the actuator moves upward. When control signal decreases, the actuator moves downward. (factory default)
S2-6	Setting of signal interruption mode	ON	DW: When the control signal type is set as voltage or current, the actuator will automatically provide a minimum control signal if the signal cable is cut. (factory default)
		OFF	UP: 1) When the control signal type is set as voltage, the actuator will automatically provide a maximum control signal if the signal cable is cut. 2) When the control signal is set as current, actuator will automatically provide a minimal signal when the signal cable is cut.
S2-7	Setting of self-adaption mode	ON	DF: In power-on self-adaption mode. (factory default)
		OFF	RF: In manual self-adaption mode.
S2-8	Setting of control mode	ON	Floating control.
		OFF	Modulating control. (factory default)
S2-9	Reserved		
S2-10	Speed setting	ON	High speed: 600N - 3s/mm, 1800N - 2s/mm.
		OFF	Low speed: 600N - 4s/mm, 1800N - 3s/mm.(factory default)